

MS-860

The Microscan® MS-860 makes reading bar codes and stacked 2D codes easy.

Push-button calibration and a fully programmable feature set enable you to quickly and easily configure the scanner to meet your needs. Raster settings are programmable to read multiple symbols at different locations or at varying distances.

Easy to setup, the **MS-860's** push-button setup will save installers of all skill levels valuable time. Pressing the EZ button initiates the calibration process to optimize the **MS-860's** settings for each bar code type and setup. This maximizes performance and can be done onsite.

By combining flexible features with ease of use, the **MS-860** is adaptable to a wide variety of bar code applications across multiple industries with operators of varying experience levels.



INDUSTRIAL BAR CODE SCANNER

Calibration

Out of the box setup is simplified with the 860's unique calibration feature. Simply place your bar code in front of the scanner and push the EZ button to initiate calibration. Motor speed, gain, tracking, and laser power are all self-calibrated in the MS-860 to optimize settings specifically to your bar code.

Intelligent Raster

In addition to sweep angle and speed controls, the MS-860's programmable raster features intelligent auto framing technology. Advanced software will automatically frame the raster height and width of the laser to match the bar code symbol. This allows the scanner to selectively target specific bar codes in a single read cycle.

Push-Button Setup

The EZ button puts power at your fingertips. Three programmable positions can be used to quickly perform complex tasks. EZ button user-selectable functions include:

- Read Rate
- Calibration
- Auto Framing (laser and raster)
- Save for Power-on
- Sleep Mode
- Load New Master

High Scan Speed and Long Read Range

The MS-860's high scan speed coupled with long read range and wide sweep angle provide maximum flexibility for addressing applications with multiple symbols, different locations, or a wide range of distances.

Real-Time Feedback

Illuminated LEDs on the side of the scanner and a green flash LED projecting from the front window provide visual confirmation of the scanner's performance. The green flash LED is visible within a complete 360 degree radius from the scanner.













ESP® Easy Setup Program

ESP® is Microscan's software to configure, test, and operate Microscan readers. ESP® includes a fully functional terminal program and is compatible with Windows 98, NT, 2000, and XP

Symbologies

Like all Microscan scanners, the MS-860 reads virtually all widely used symbologies, including:

- PDF417  • RSS/Composite 
- MicroPDF417  • Pharmacode 
- Code 39  • Code 128 
- Code 93  • Codabar 
- UPC/EAN  • I2 of 5 



Bar Code Programming

Changing scanner configuration on the shop floor can be as simple as presenting a bar code and pushing the EZ button. This feature makes it simple to replicate a setup on multiple MS-860 scanners.

MS-860 EZ INDUSTRIAL BAR CODE SCANNER

SPECIFICATIONS AND OPTIONS

MECHANICAL

Height: 4.28" (109 mm)
Width: 3.74" (95 mm)
Depth: 1.76" (45 mm)
Weight: 16 oz. (453 g)

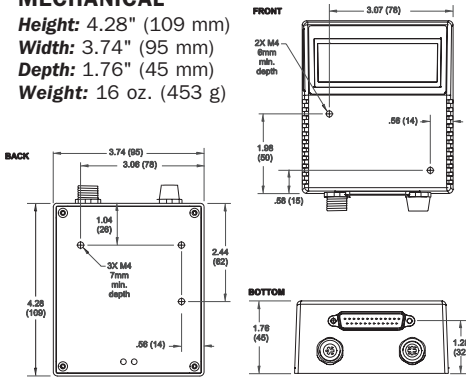

ENVIRONMENTAL

Enclosure: IP65
Operating temperature: 0° to 50°C (32° to 122°F)
Storage temperature: -50° to 75°C (-63° to 167°F)
Humidity: Up to 90% (non-condensing)

EMISSIONS

Heavy industrial: EN61000-6-2:2001
Radiated and Conducted emissions: EN 55022:1998 + A1:2000 + A2:2003 (Limits & Methods: ITE Disturbances)
General immunity residential: EN55024:1998 + A1:2001 + A2:2003

LASER LIGHT

Type: Semiconductor visible laser diode (650 nm nominal)
Operating life: 50,000 hours @ 25°C
Safety class: CDRH Class II

SCANNING PARAMETERS

Scanner mirror type: Rotating, 10-faceted
Scan rate: Adjustable from 300 to 1200 scans/second (default = 500 sps)
Scan width angle: Typically 60°
Pitch: ±50° maximum
Skew: ±40° maximum
Label contrast: 25% min. absolute dark to light at 650 nm wavelength
Raster mirror performance:

Raster sweep angle	Maximum sweeps per second
1°-10°	80
11°-20°	60
21°-34° (max.)	40
35°-36° (max.)	20

Communication

Interface: RS-232, RS-422/485, Daisy chain and Auxiliary port capable

SYMBOLOGIES

Standard: Code 128, Code 39, Code 93, Codabar, RSS (Composite), Interleaved 2 of 5, UPC/EAN, PDF417, MicroPDF, and Pharmacode

ELECTRICAL

Power Requirement: 10-28 VDC, 200 mV p-p max. ripple, 110 mA at 24 VDC (typ.)
Trigger, New Master, Input 1: Optoisolated, 5-28V rated, (12 mA at 24 VDC)
Outputs (1, 2, 3): Optoisolated, 1-28 VDC rated, (I_{CE} <100 mA at 24 VDC, current limited by user)

SAFETY CERTIFICATIONS

CDRH, CE, UL/cUL

ISO CERTIFICATION

Issued by RWTüV, USA Inc.
 ISO 9001:2000 – Cert No. 03-1212

READ RANGES¹

Narrow-bar-width	Extended Range (350-500 decodes/sec)
Far Focus	
.040" (1 mm)	19 to 47" (482 to 1193 mm)
.030" (.762 mm)	21 to 42" (533 to 1066 mm)
.020" (.508 mm)	25 to 41" (635 to 1041 mm)
Middle Focus	
.015" (.381 mm)	11 to 21" (280 to 533 mm)
.010" (.254 mm)	14 to 17" (356 to 431 mm)
Near Focus	
.015" (.381 mm)	2 to 16" (51 to 406 mm)
.010" (.254 mm)	3 to 11" (77 to 279 mm)

Narrow-bar-width	Low Density (450-500 decodes/sec)
.040" (1.02 mm)	2" to 28" (50 to 711 mm)
.030" (.762 mm)	2 to 24" (50 to 610 mm)
.020" (.508 mm)	2.5 to 20" (64 to 508 mm)
.015" (.381 mm)	4 to 18" (102 to 457 mm)
.010" (.254 mm)	6.5 to 13.25" (165 to 337 mm)

Narrow-bar-width	Medium Density (450-500 decodes/sec)
.030" (.762 mm)	1 to 13" (25 to 330 mm)
.015" (.381 mm)	.5 to 9.25" (13 to 235 mm)
.010" (.254 mm)	.75 to 7.25" (19 to 184 mm)
.0075" (.190 mm)	1.5 to 5.25" (38 to 113 mm)

Narrow-bar-width	High Density (450-500 decodes/sec)
.0075" (.190 mm)	1 to 4" (25 to 102 mm)
.005" (.127 mm)	1.5 to 2.75" (38 to 70 mm)

CONNECTORS/PIN ASSIGNMENTS

Host Connector: 25-pin D-subminiature plug

Pin No.	Host RS232	Host & Aux RS232	Host RS422/485	In/Out
1	Chassis ground			
2	TxD			Out
3	RxD			
4	RTS	Aux TxD		Out
5	CTS	Aux RxD		In
6	Output 1 (+)			
7	Signal Ground			
8	Output 2 (+)			Out
9	Trigger (-)			In
10	Trigger (+)			In
11	Default configuration*			
12	Input 1 (+)			In
13			RxD (+)	In
14			TxD (-)	Out
15	Noread/Output 3 (+)			Out
16			RxD (-)	In
17	Power Ground			In
18	Power +10 to 28 VDC			In
19			TXD +	Out
20	Output 1 (-)			Out
21	Output 2 (-)			Out
22	Noread/Output 3 (-)			Out
23	Input 1 (-)			In
24	New master (-)			In
25	New master (+)			In

*The default is activated by connecting pin 11 to ground pin 7.

Trigger Connector: 4-pin MicroChange

Pin No.	Function	In/Out
1	Power + 10 to 28 VDC	Out
2	Trigger (-)	
3	Power Ground*	
4	Trigger (+)	

*Power ground: Used for power return only

Power Connector: 3-pin MicroChange

Pin No.	Function	In/Out
1	Power ground	
2	NC	
3	Power + 10 to 28 VDC	In

Extended Range Scanner Read Range/Width

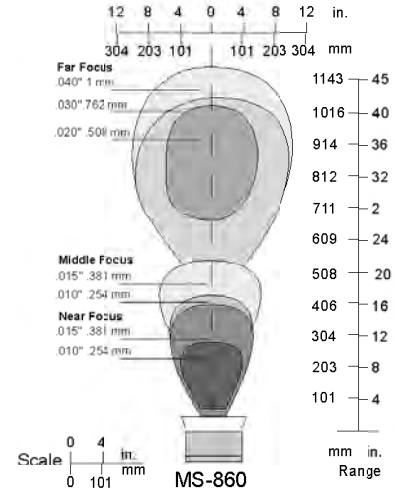

Low, Medium, High Density Scanner Read Range/Width

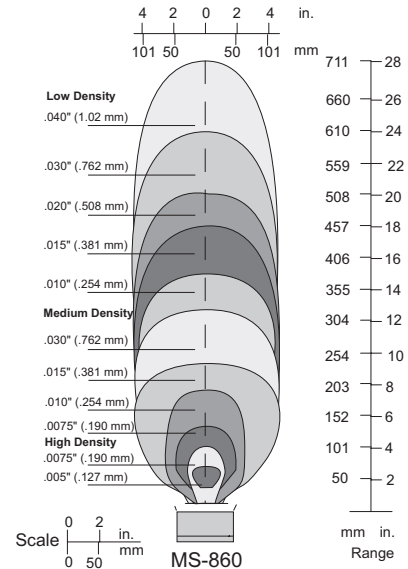

©2006 Microscan Systems, Inc. 06/06- Base D Specifications subject to change. Updates to this specification can be found on-line at www.microscan.com.

Product specifications are given for typical performance at 25°C (77°F) using grade A labels. Some performance characteristics may vary at high temperatures or other environmental extremes.

Warranty: One year limited warranty on parts and labor. Extended warranty available.



MICROSCAN®

Microscan Systems, Inc.

Tel 425 226 5700 / 800 251 7711
 Fax 425 226 8250

Microscan Europe

Tel 31 172 423360 / Fax 31 172 423366

Microscan Asia Pacific R.O.

Tel 65 6846 1214 / Fax 65 6846 4641

Part of a full range of sales tools available from our web site:

www.microscan.com

Product Information: info@microscan.com
 Tech. Support: helpdesk@microscan.com