

MS-Q QUADRUS™ HAND HELD IMAGER

The MS-Q Quadrus™ imagers are optimized to read bar codes and 2D symbols that use direct part mark (DPM) methods. It is the most aggressive hand held imager available for decoding symbols on low contrast substrates such as metal, plastic, rubber, and glass with marking methods such as dot peen and laser/chemical etch.

Containing custom optics and Microscan's Quadrus decode algorithms, the MS-Q combines the decoding power of Microscan's popular smart camera Quadrus EZ™ into a portable hand held device.

QUADRUS™ IMAGER FOR DIRECT MARK READING

Optical Options:

The MS-Q Quadrus™ hand held imager is available in two optical options:

- The high resolution version is custom designed to optimize resolution for reading small 2D symbols in direct part mark applications.
- The standard resolution version is suitable for reading all printed bar code methods plus many applications with directly marked symbols.



LightRay Optics Accessory:

Microscan's patented **LightRay Optics** solution further enhances the MS-Q's ability to read directly marked parts. By directing the illumination toward the symbol at off-axis angles, the **LightRay Optics** increase symbol contrast and filters out texture noise. The LightRay Optics are designed so that the MS-Q is positioned at the correct focal distance and angle. No training is needed to find the best angles for reading low contrast symbols. Either optical accessory easily attaches onto the end of the MS-Q. Two options are available: the LightRay 100 Series and the LightRay 200 Series.



*LightRay 100 Series
generates off-axis
diffuse illumination*



*LightRay 200 Series
generates dark field
illumination*

Ease of Use:

All MS-Q imagers feature point-and-click targeting with a red laser spot to quickly center the symbol in the field of view. Beeper, vibrator, and multi-purpose LEDs provide real-time feedback to signal successful decoding.

Applications:

The MS-Q Quadrus provides outstanding performance on challenging directly marked 2D codes.

Automotive and Aerospace: reads codes directly marked on steel, iron, aluminum, rubber, and glass parts by laser etch, dot peen, metal stamp, and other methods.

Electronics: reads codes laser etched on printed circuit boards and components.

Department of Defense: reads UID codes on a variety of substrates. Software enables MS-Q to verify UID code format for suppliers and constructs the UID string for DoD operators.

System Integration:

All MS-Q imagers are available in 3 configuration options:

- **Batch:** A wireless way to collect thousands of decoded symbols for later download, capable of performing more than 4000 reads from a single battery charge and buffer a minimum of 1 MB of data in non-volatile memory.*
- **Cabled:** Cabled units include USB, RS-232, and PS2.
- **Bluetooth:** Wireless data transmission using Bluetooth™ class 1 radio with a 328' (100 m) operating range.

*For batch and Bluetooth options a 1300 mA Lithium-Ion battery is included.

Symbologies:

The MS-Q Quadrus™ imager reads all standard linear bar codes plus:

2D Symbologies:

- Data Matrix (ECC 0-200)
- QR Code
- MaxiCode
- Aztec Code

Stacked Symbologies:

- Micro PDF417
- PDF417 (Macro support)

MICROSCAN®

MS-Q QUADRUS™ IMAGER FOR DIRECT PART MARK READING

Specifications and Options

IMAGER MECHANICAL

Height: 1.3" (33 mm)
Width: 1.8" (46 mm)
Depth: 4.3" (109 mm)
Weight: 2.5 oz. (71.5 g),
 not including cable

HANDLE MECHANICAL

Height: 3.8" (96.5 mm)
Width: 1.2" (30 mm)
Depth: 1.4" (36 mm)
Weight: 1.2 oz. (59.8 g)

ADDITIONAL PHYSICAL CHARACTERISTICS

Battery Weight: 2.1 oz. (59.5 g)
Battery Blank: .5 oz. (13.6 g)
Cable Length: 6' (1.8 m)

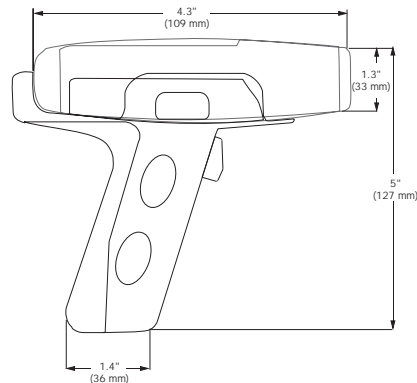

ENVIRONMENTAL

Operating Temperature: 0° to 40°C (32° to 104°F)
Storage Temperature: -20° to 60° C (-4 to 140°F)
Humidity: 5 to 90% (non-condensing)

CE STANDARDS

Immunity: EN 55024
ESD: EN 61000-4-2 **Radiated RF:** EN61000-4-3
Keyed Carrier: ENV50204 **RF:** EN61000-4-4
Conducted RF: EN61000-4-6,
Emissions: EN55022, Class B Radiated,
 Class B Conducted

LIGHT COLLECTION OPTIONS

Sensor: CMOS, progressive scan, 1.33 MP (1024 by 1280), 256 gray scale

Standard Resolution Field of View:

Near: 21.5° horizontal by 16.2° vertical
 Far: 22.9° horizontal by 11.6° vertical

High Resolution Field of View:

Near & Far: 21° horizontal by 13° vertical

Standard Resolution Focal Point:

Near: 4" (101.6 mm)
 Far: 9" (228.6 mm)

High Resolution Focal Point:

Near: 2.75" (70 mm)
 Far: 4.5" (115 mm)

Sensor Array:

Near Field: 1024 by 640 (default)
 Far Field: 1024 by 640 (default)



SYMBOLGY TYPES

Linear Bar Codes: Code 39, Code 128, I2 of 5, RSS, UPC/EAN, Codabar, Codablock F, Code 93, PLANET, PostNet, KIX Code, Postal codes
Stacked Symbolgies: PDF417, Micro PDF417
2D Symbolgies: Data Matrix, MaxiCode, Aztec Code, QR Code
 Note: Quadrus mode decodes Data Matrix ECC 0-200 and QR code only.
 Basic mode decodes Data Matrix ECC 200 plus all other listed symbolgies.

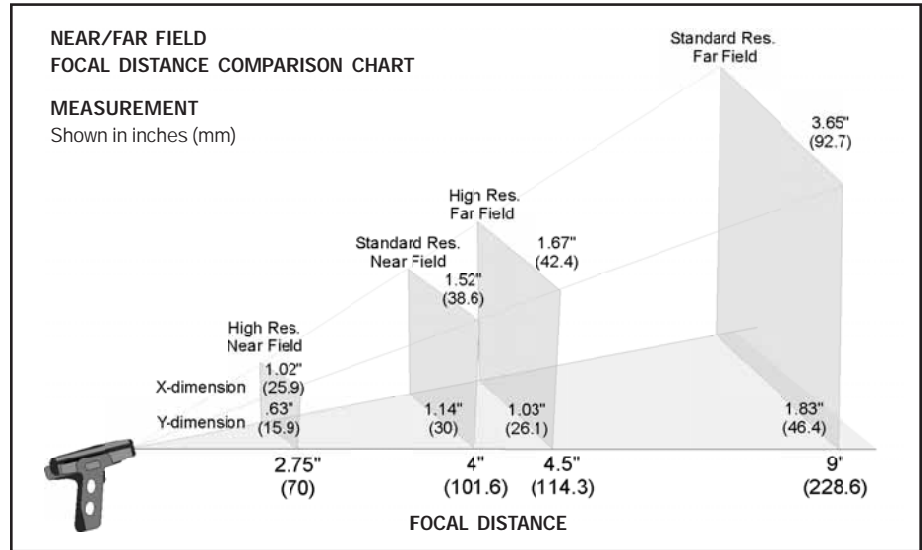

READ RANGES, STANDARD RESOLUTION

Narrow Bar-Width	Read Range Distance
.0075" (.191 mm)	3.2 to 3.9" (81 to 99 mm)
.015" (.381 mm)	3.0 to 9.0" (76 to 229 mm)
.020" (.508 mm)	3.0 to 11.5" (76 to 292 mm)

READ RANGES, HIGH RESOLUTION

Narrow Bar-Width	Read Range Distance
.005" (.127 mm)	1.75 to 2.5" (44.4 to 63.5 mm)
.0075" (.191 mm)	1.75 to 4" (44.4 to 101.6 mm)
.010" (.254 mm)	1.75 to 4.75" (44.4 to 102.6 mm)
.015" (.381 mm)	1.75 to 6" (44.4 to 152.3 mm)
.020" (.508 mm)	1.75 to 6.5" (44.4 to 165.1 mm)

READ RANGES WITH LIGHTRAY OPTICS

LightRay Options	Read Range Distance
LightRay 100 Series	Contact to .25" (6.35 mm)
LightRay 200 Series	Contact to .25" (6.35 mm)

Ranges based on Grade A, Data Matrix symbols.

READ PARAMETERS

Pitch: ±60° (front to back) **Skew:** ±60° **Tilt:** 360°
Focal Range: 1 to 20" (25 to 508 mm)
Rotational Tolerance: ±180°
Print Contrast Resolution: 25 percent (bar codes); 35 percent (PDF417); absolute dark/light reflectance differential, measure at 650 nm.
Target Beam: Visible Laser Diode at 630 nm. Class 2
Ambient Light Immunity: Sunlight: Up to 9,000 ft-candles 96,890 lux
Shock: Withstands multiple drops of 6.5' (2 meters) to concrete

INDICATORS

LED Indicators: Memory status, Battery power, Successful decode, and Connection status
Programmable Indicators: Beeper or Vibrate option; communicates scanner operation and communication functions to user

IMAGE OUTPUT OPTIONS

Format: Jpeg, Raw (uncompressed)
Time Stamp: Interval logging

COMMUNICATION PROTOCOLS

Standard Interface: USB
Optional Interface: RS-232, Bluetooth Class 1
 Radio at 328' (100 m), PS2

ELECTRICAL

Power Requirements: 5 VDC (mA)
Typical: 310 **Peak:** 310 **Sleep:** 3

Bluetooth Radio at 295' (90 m) away (mA):

Typical: 280 **Peak:** 350 **Idle:** 96 **Sleep:** 3

Bluetooth Radio at 33' (10 m) away (mA):

Typical: 260 **Peak:** 350 **Idle:** 96 **Sleep:** 3
Battery Life: Battery with radio will support 4000 read/transmits per charge including 8 hours of standby interval.

FIELD OF VIEW, STANDARD RESOLUTION

Near Field of View	
Distance (inches/mm)	Field of View Size (1024 x 640 pixel, Default)
4" (101.6)	1.52 x 1.14" (38.6 x 30 mm)
Far Field of View	
9" (228.6)	3.65 x 1.83" (92.7 x 46.4 mm)

FIELD OF VIEW, HIGH RESOLUTION

Near Field of View	
Distance (inches/mm)	Field of View Size (1024 x 640 pixel, Default)
2" (50.8)	.74 x .46" (18.8 x 11.6 mm)
2.5" (63.5)	.93 x .57" (23.5 x 14.5 mm)
2.75" (69.9)	1.02 x .63" (25.9 x 15.9 mm)
3" (76.2)	1.11 x .68" (28.3 x 17.4 mm)
3.5" (88.9)	1.3 x .80" (33 x 20.3 mm)
4" (101.6)	1.48 x .91" (37.7 x 23.2 mm)
Far Field of View	
2" (50.8)	.74 x .46" (18.8 x 11.6 mm)
2.5" (63.5)	.93 x .57" (23.5 x 14.5 mm)
3" (76.2)	1.11 x .68" (28.2 x 17.4 mm)
3.5" (88.9)	1.3 x .80" (32.9 x 20.3 mm)
4" (101.6)	1.48 x .91" (37.6 x 23.2 mm)
4.5" (114.3)	1.67 x 1.03" (42.4 x 26.1 mm)
5" (127)	1.85 x 1.14" (47.1 x 28.9 mm)
5.5" (139.7)	2.04 x 1.25" (51.8 x 31.8 mm)
6" (152.7)	2.22 x 1.37" (56.5 x 34.7 mm)
6.5" (165.1)	2.41 x 1.48" (61.2 x 37.6 mm)

FIELD OF VIEW, LIGHTRAY OPTICS*

LightRay Options	Field of View Size
LightRay 100 Series	Small Circular .75" (19.1 mm) Dia.
	Large Circular TBD
LightRay 200 Series	Small Circular .75" (19.1 mm) Dia.
	Large Circular TBD

*Patents: U.S. 6,352,204 and 6,854,650

SAFETY CERTIFICATIONS

FCC, CE

ISO CERTIFICATION

Issued by RWTÜV, USA Inc.
 ISO 9001:2000 - Cert No. 03-1212

MICROSCAN®

Microscan Systems, Inc.
 Tel 425 226 5700/ 800 251 7711
 Fax 425 226 8250

Microscan Europe

Tel 31 172 423360/ Fax 31 172 423366

Microscan Asia Pacific R.O.

Tel 65 6846 1214 / Fax 65 6846 4641

www.microscan.com

www.quadrus-ez.com

Tech Support: helpdesk@microscan.com

Product Information: info@microscan.com

©2005 Microscan Systems, Inc.

Specifications subject to change - Base F